



CAMPING PODS

INSULATED CAMPING PODS

SLEEPING BARRELS

CAMPING CABINS

DOUBLE CAMPING CABINS

CAMPING PRODUCTS



REAL PRODUCTS FOR REAL PEOPLE

We have gathered a team of professionals whose main goal is to design, produce and sell high quality wooden products and accessories for leisure.

ABOUT CAMPING PRODUCTS

TIMBER

SPRUCE

We mainly use Nordic spruce, which comes from Scandinavia. Every single board used for our camping product has its own individual character and history, and this makes our product a real natural and unique product.

The colours range from creamy white to light yellow and to red-brown. Heartwood is not distinct from sapwood. Spruce is straight-grained with thin and regular texture. Resin canals are rather common. The wood is soft, low in weight and has medium density. The strength properties are good. Sawing and machining is easy, also assembling.

THERMOWOOD

Thermowood is a natural and renewable resource for construction, but has greater stability and resistance to rot making it a far more dependable product. This is now ideal for cladding buildings as it is lower cost than some of the traditional cladding timbers, but has comparable longevity and greater stability than other timbers products. By selecting your camping product with thermowood cladding you ensure a long lifespan for the product and less maintenance time and cost to you.



Timber for Camping Pod walls. 1. Thermowood (38 mm). 2. Spruce (38 mm). 3. Spruce (58 mm)

ROOF SHINGLES

6 layer bitumen tiles consists of durable and highly resistant fiber glass base coated with polymer-reinforced bitumen mix made of high quality bitumen and aggregate. The top layer of tiles is surfaced with mineral granules that lend color to the tiles and ensure high UV protection and other weather conditions resistance qualities.

The granules are painted in high temperature using thermal method pigment being burned-in into the surface of granules what guarantees long durability of the color. The bottom of tiles is coated with adhesive polymer-reinforced bitumen layer protected with easily removed silicon membrane.

AVAILABLE ROOF COLOR



Black shingles

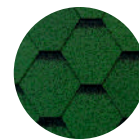

Green shingles



Red shingles

RECOMMENDATIONS FOR WOOD CARE

You should not forget that wood is a natural material, it changes and moves depending on weather conditions. Large and small cracks, color tone differences and other changes, as well as a changing structure of wood are not defects, but a result of wood growing and a feature of wood as a natural material. Natural wood (not impregnated) becomes grayish after being left untouched for a while, and can turn blue and become moldy. You should immediately process it with wood preservative to protect the wooden parts of our manufactured products.

We definitely recommend that you process the door and windows with a wood preservative, and do it on both sides (inside and outside), because the doors and windows can deform. Also, you should pre-treat the Camping Cabins floor

panels with a wood preservative, especially the bottom sides of the panels, to which you will no longer have access when the Cabin is assembled. Only this will prevent moisture penetration.

In general, we recommend for the conclusive finishing a weather protection paint that will protect wood from moisture and UV radiation after the product is assembled.

Consult a specialist regarding paints suitable for unprocessed softwood and follow the paint manufacturer's instructions. Your Camping Product service life will be much longer after it will be properly painted. We recommend that you inspect your product thoroughly once every six months.

CAMPING PODS

COMFORTABLE OUTDOOR LIVING

Camping Pods are a great choice for tourists and holiday makers who want to relax after an adventure. Because of the feeling of a home's atmosphere in outdoor setting, this product is very much liked by camping owners or festival organizers.



CAMPING POD 2.4 x 4



One big room inside

French type doors. Double glass units are used, they windows ensure lower heat transfer to the outside, a lot of light coming inside and long usage time

Small terrace: (W x D) 600 x 2321 mm



Perfect size and design, functional and of high quality camping pod is ideal for a camping place. It has a 3.2 m length room where you can sleep and/or rest and have a small lunch.

Camping pod is made from spruce. Thickness of the camping pod walls is 38 mm; thickness of the solid wood flooring is 28 mm. Camping pod is 2.4 m wide and almost 2.6 m high.

STANDARD SET

- Pod made from spruce;
- Roof covered with bitumen shingles of your selected color;
- One opening window in the back wall;
- Double doors with a lock and the double glass windows;
- One large room inside.

OPTIONS

ROOF COLOR



Black shingles

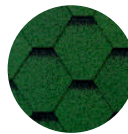

Green shingles



Red shingles

LAYOUT

- Pod with terrace 0.6 m: 3.2 m length room.
- Pod without terrace: 3.7 m length room.

THICKNESS OF THE WALL

- 38 mm thick spruce wood: standard;
- 58 mm thick spruce wood: optional.
- 38 mm thick thermowood: optional.

POD BACK WALL

- 38 mm spruce wood wall: standard;
- Full glass back wall: optional (10 mm tempered glass).

TRANSPORTATION AND ASSEMBLY

The Camping Pod is delivered to a customer fully assembled or not-assembled, but fully complete, with detailed assembly instructions, drawings and packed on a pallet (KIT).

Two people can assemble camping pod 2.2 x 4 m in 8 hours.

Size of a assembled cargo (L x W x H):
4.1 x 2.4 x 2.6 m.

Size of a KIT (L x W x H): 4.1 x 1.2 x 2.6 m.

INSIDE PLAN

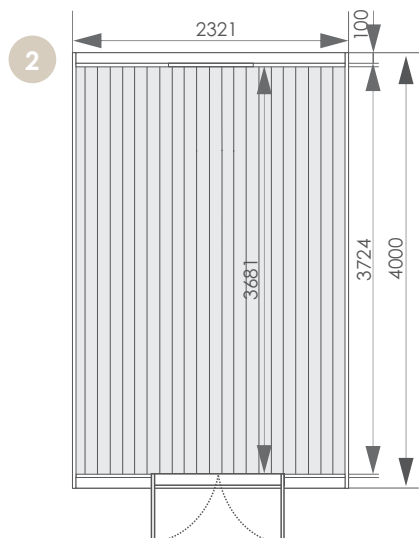
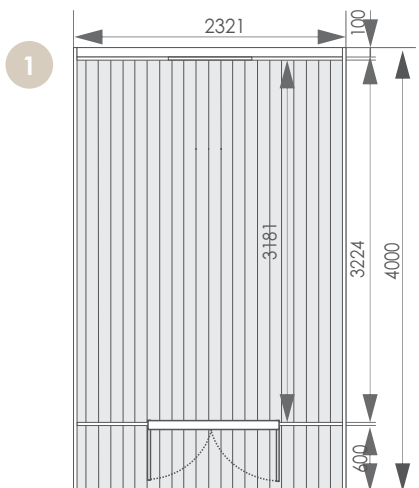

TECHNICAL SPECIFICATION

Shape	Pod
External dimension (L x W)	2321 x 4000 mm
Total high (H)	2560 mm
Inside area	7.5 m ²
Size of doors (W x H)	1020 x 1920 mm
Size of window (W x H)	678 x 714 mm
Number of windows	1
Number of opening windows	1
Group of people	2-4 persons
Weight	1300 kg
Wood	Spruce
Wall thickness	38 mm

CAMPING POD 2.4 x 4.8



Recommended furnishings:

In living room 2 wooden poufs, table and bench; Bedroom with double wooden bed which can be transformed into a sofa.

Small terrace:
(W x D) 600 x 2321 mm.

Inside are two rooms:
living room and bedroom.



Try camping in a high quality camping pod, it is ideal choice for a camping place. Pod has a small entrance and two rooms inside: a 2 m length sleeping room and 2 m long sitting room.

Camping pod is made from spruce. Thickness of the camping pod walls is 38 mm; thickness of the solid wood flooring is 28 mm.

STANDARD SET

- Pod made from spruce;
- Roof covered with bitumen shingles of your selected color;
- Opening window in the back wall;
- Double doors with a lock and the double glass windows;
- Two rooms inside: a sleeping and a sitting room;
- Wall partition with entrance.

OPTIONS

ROOF COLOR



Black shingles

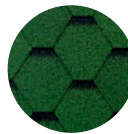

Green shingles



Red shingles

LAYOUT

- Pod with terrace 0.6 m: 1st room 1.9 m / 2nd room 2 m;
- Pod without terrace: 1st room 2.4 m / 2nd room 2 m.

THICKNESS OF THE WALL

- 38 mm thick spruce wood: standard;
- 58 mm thick spruce wood: optional;
- 38 mm thick thermowood: optional.

POD BACK WALL

- 38 mm spruce wood wall: standard;
- Full glass back wall: optional (10 mm tempered glass).

TRANSPORTATION AND ASSEMBLY

The Camping Pod is delivered to a customer fully assembled or not-assembled, but fully complete, with detailed assembly instructions, drawings and packed on a pallet (KIT).

Two people can assemble Camping Pod 2.4 x 4.8 m in 10 hours.

Size of a assembled cargo (L x W x H):
4.9 x 2.4 x 2.6 m.

Size of a KIT (L x W x H): 4.9 x 1.2 x 2.6 m.

TECHNICAL SPECIFICATION

Shape	Pod
External dimension (W x L)	2321 x 4800 mm
Total high (H)	2580 mm
Inside area	9.3 m ²
Size of windows (W x H)	678 x 714 mm
Size of doors (W x H)	1020 x 1920 mm
Size of terrace (W x D)	2321 x 600 mm
Number of windows	1
Number of opening windows	1
Group of people	2-4 persons
Weight	1880 kg
Wood	Spruce
Wall thickness	38 mm

INSIDE PLAN

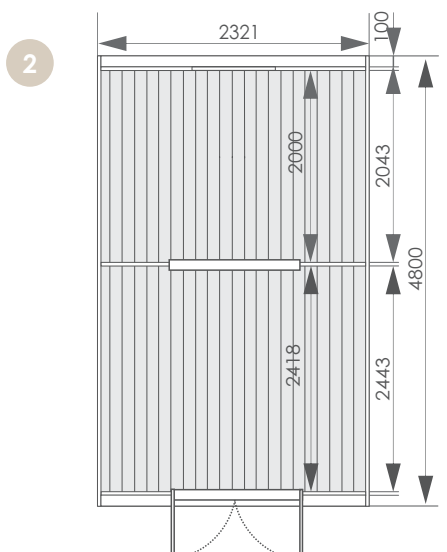
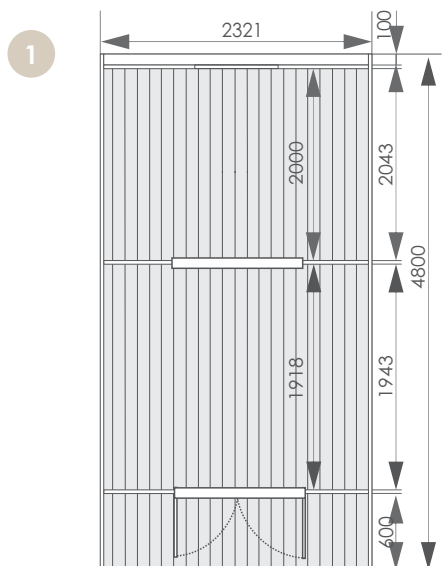

CAMPING POD 2.4 x 4.8



INSULATION

Wall insulation

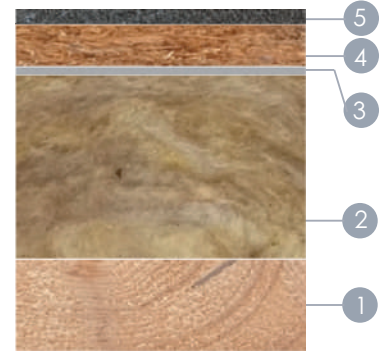

1. Wall made from spruce (38 mm). 2. Stonewool (50 mm). 3. Wind insulating film (1mm). 4. OSB panel (8 mm). 5. Bitumen shingles (3 mm).

Panel insulation

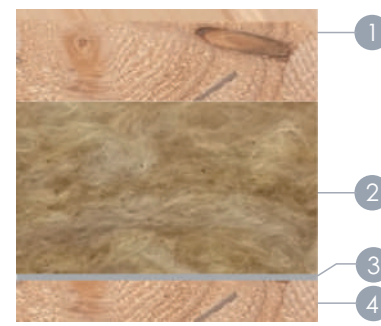

1. Wall made from spruce (38 mm). 2. Stonewool (50 mm). 3. Wind insulating film (1mm). 4. Wall made from spruce (12 mm).

Floor insulation

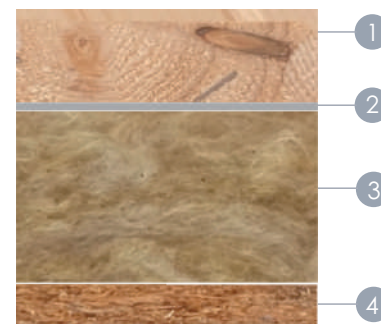

1. Floor made from spruce (28 mm). 2. Wind insulating film (1mm). 3. Stonewool (50 mm). 4. OSB panel (12 mm).

INSIDE PLAN

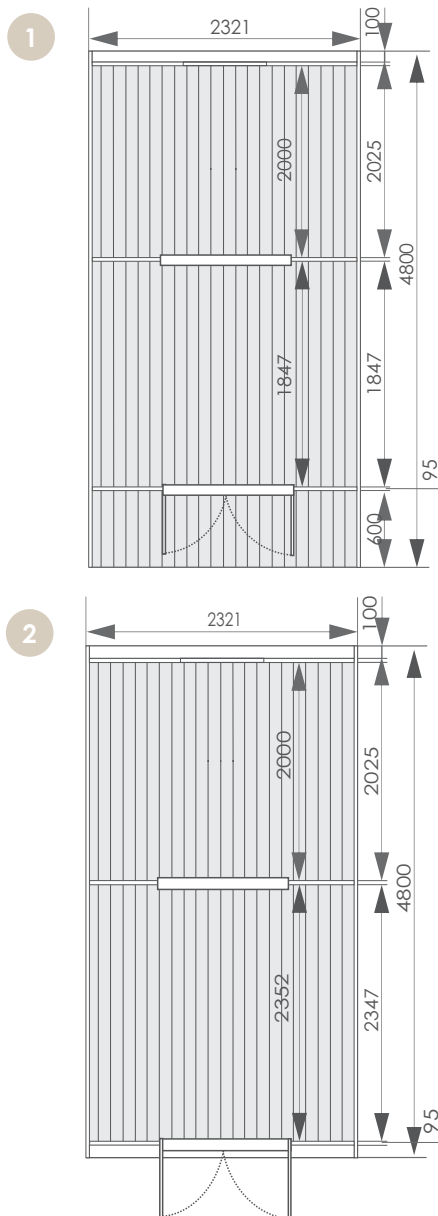

STANDARD SET

- Pod made from spruce with insulated walls;
- Roof covered with bitumen shingles of your selected color;
- One opening window in the back wall;
- Double doors with a lock and the double glass windows;
- Two rooms inside: sleeping and living room;
- Wall partition with the entrance.

TECHNICAL SPECIFICATION

Shape	Pod
External dimension (W x L)	2321 x 4800 mm
Size of terrace (W x D)	2321 x 600 mm
Total high (H)	2452 mm
Inside area	9 m ²
Size of window (W x H)	678 x 714 mm
Size of doors (W x H)	1020 x 1920 mm
Number of window	1 double
Number of opening window	1
Group of people	4-8 persons
Weight	1600 kg (without furnitures)
Wood	Spruce
Wall thickness	38 mm

TRANSPORTATION AND ASSEMBLY

The Camping Pod is delivered to a customer **assembled** or **not-assembled**, but fully complete, with detailed assembly instructions and drawings, and packed on a pallet (KIT). Two people can assemble camping pod in 12 hours.
Size of KIT (L x W x H): 4.9 x 1.2 x 2.6 m.,
Size of assembled cargo is (L x W x H): 4.9 x 2.4 x 2.6 m.

LAYOUT

- With terrace 0.6 m: 1st room 1.8 m; 2nd room 2 m length;
- Without terrace: 1st room 2.3 m and 2nd room 2 m length.

ROOF COLOR



CAMPING POD 3.2 x 4.8



INSULATION

Wall insulation

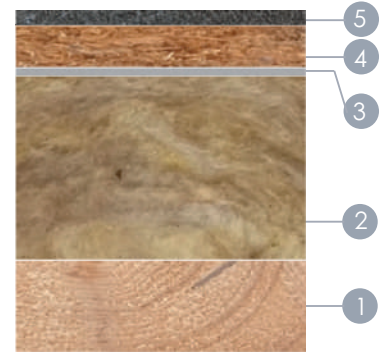

1. Wall made from spruce (38 mm). 2. Stonewool (50 mm). 3. Wind insulating film (1mm). 4. OSB panel (8 mm). 5. Bitumen shingles (3 mm).

Panel insulation

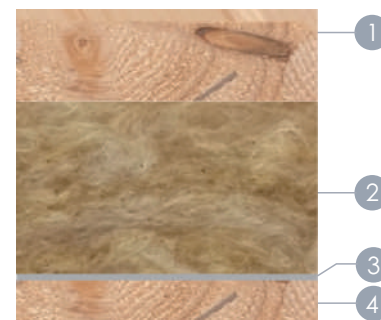

1. Wall made from spruce (38 mm). 2. Stonewool (50 mm). 3. Wind insulating film (1mm). 4. Wall made from spruce (12 mm).

Floor insulation

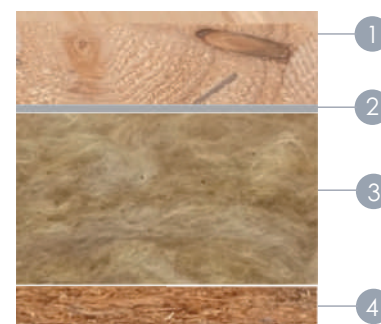

1. Floor made from spruce (28 mm). 2. Wind insulating film (1mm). 3. Stonewool (50 mm). 4. OSB panel (12 mm).

INSIDE PLAN

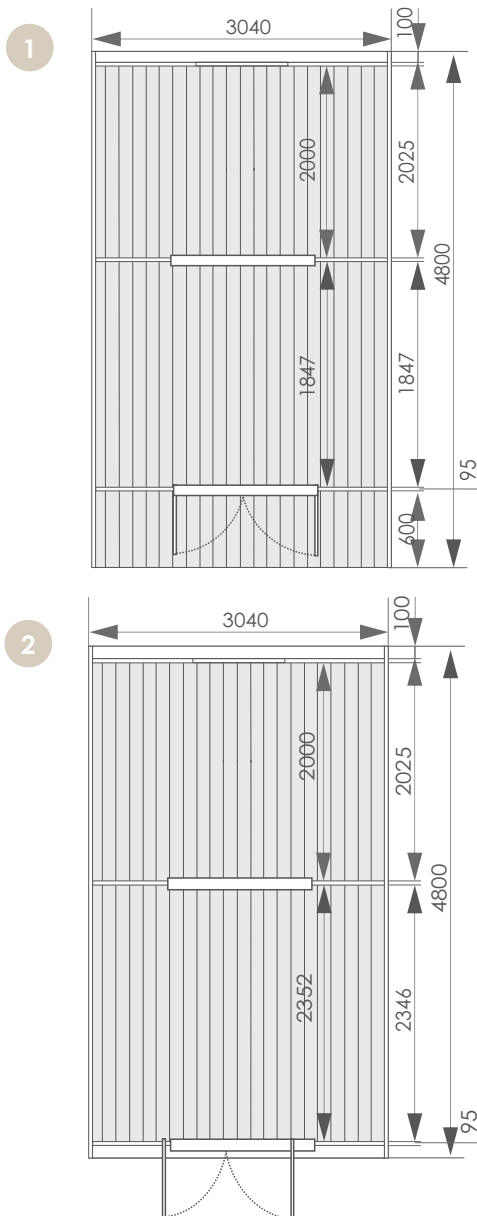

STANDARD SET

Pod made from spruce with insulated walls;

Roof covered with bitumen shingles of your selected color;

One opening double window in the back wall;

Double doors with a lock and the double glass windows;

Two rooms inside: sleeping and living room;

Wall partition with the entrance.

TECHNICAL SPECIFICATION

Shape	Pod
External dimension (W x L)	3040 x 4800 mm
Total high (H)	2560 mm
Inside area	13.4 m ²
Wall thickness	38 mm
Size of door (W x H)	1020 x 1920 mm
Size of window (W x H)	925 x 950 mm
Number of windows	1
Number of opening windows	1
Group of people	4-8 persons
Weight	1800 kg (with furnitures 2650 kg)
Wood	Spruce

TRANSPORTATION AND ASSEMBLY

The Camping Pod is delivered to a customer **not assembled**, but fully complete, with detailed assembly instructions and drawings, and packed on a pallet (KIT).

Two people can assemble camping pod in 12 hours.

Size of KIT (L x W x H): 4.9 x 1.2 x 2.6 m.

LAYOUT

1. **With terrace 0.6 m:** 1st room 1.8 m; 2nd room 2 m length;
2. **Without terrace:** 1st room 2.3 m and 2nd room 2 m length.

ROOF COLOR



CAMPING POD 3.2 x 5.9



This Insulated Glamping pod 3.2 x 5.8 m is a luxury haven for up to 2-3 people. The layout is done so that you have an intimate and private space for the toilet and shower. Large living space is divided into spaces according to need.

INSULATION

Wall insulation

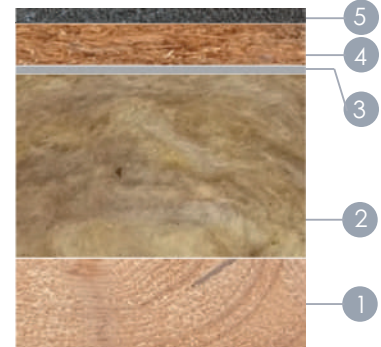

1. Wall made from spruce (38 mm). 2. Stonewool (50 mm). 3. Wind insulating film (1mm). 4. OSB panel (8 mm). 5. Bitumen shingles (3 mm).

Panel insulation

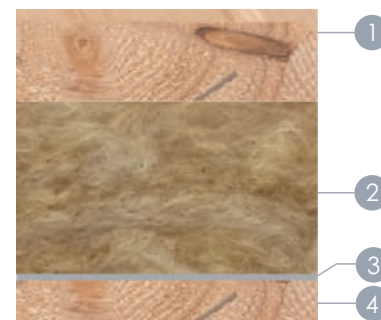

1. Wall made from spruce (38 mm). 2. Stonewool (50 mm). 3. Wind insulating film (1mm). 4. Wall made from spruce (12 mm).

Floor insulation

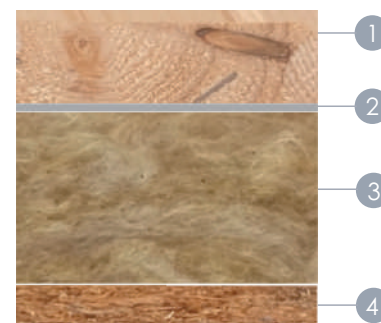

1. Floor made from spruce (28 mm). 2. Wind insulating film (1mm). 3. Stonewool (50 mm). 4. OSB panel (12 mm).

STANDARD SET

- Pod made from spruce with insulated walls;
- Insulated floor from 28 mm spruce boards;
- Inside wall dividing sleeping and living zones;
- Roof covered with bitumen shingles of your selected color;
- One double opening window in the back wall;
- Two opening windows in the front wall;
- French style double glazed doors with the lock and standard handle in the front;
- Closet or pantry area - 0.39 m²;
- Place for mini kitchen and shelves for you things;
- Large living room area for double and single beds;
- WC/shower room.

TECHNICAL SPECIFICATION

Shape	Pod
External dimension (W x L)	3200 x 5900 mm
Total high (H)	2560 mm
Inside area (total)	15.80 m ²
Inside area of WC/Shower room	3.04 m ²
Wall thickness	38 mm
Size of door (W x H)	1020 x 1920 mm
Size of double window (W x H)	678 x 714 mm
Size of front widows (W x H)	380 x 657 mm
Number of windows	3
Number of opening windows	3
Group of people	2-3 persons
Wood	Spruce

INSIDE PLAN

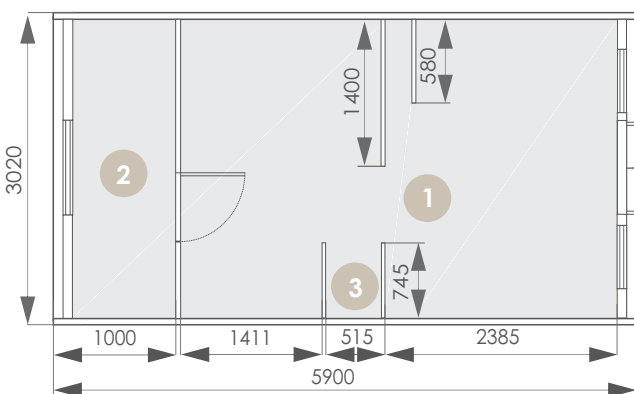

At the entrance, a cozy living area with a seating area. There will definitely fit a comfortable coffee table with puffs, and of course a single bed that can perfectly turn in to the bench. There is also a place for a mini kitchen and a large double bed for your relaxation.

For more information about the furniture please check in accessories section.

ROOF COLOR



TRANSPORTATION AND ASSEMBLY

The Camping Pod is delivered to a customer **not-assembled**, but fully complete, with detailed assembly instructions and drawings, and packed on a pallet (KIT). Two people can assemble camping pod in 12 hours. **Size of KIT (L x W x H):** 5.9 x 1.2 x 2.6 m.

LAYOUT

- 1. Living space area: 12.34 m²
- 2. Shower and WC room: 3.04 m²
- 3. Wardrobe area: 0.39 m²



The front of Insulated Camping Pod 3.2 x 5.9 m



The interior of Insulated Camping Pod 3.2 x 5.9 m



Shelves are included in the standard set



Entrance to the WC/shower room





WC room in Insulated Camping Pod 3.2 x 5.8 m.



Closet included in standard set of pod. Kitchen set is available as option in Insulated Camping Pod 3.2 x 5.9 m

OTHER SIZE OF CAMPING POD

These are several sizes for tiny - one or comfortable two rooms camping pod from spruce. We also offered 5 different sizes of camping pods from thermowood. Not all of these camping pods can be delivered to a customer assembled.

AVAILABLE OTHER SIZES OF CAMPING PODS

Product	Inside area:	Size:	Product package	Standard set:	Timber	Other
Camping Pod 2.4 x 2.4 m NOT INSULATED	5 m ²	2 people	KIT: 2.5 x 1.2 x 2.6 m Assembled: 2.5 x 2.4 x 2.6m	Pod made from spruce; Roof covered with bitumen shingles of your selected color; Opening window in the back wall; Double doors with a lock and the double glass windows. Price is without furniture.	North spruce/ Thermowood	Without terrace One room inside
Camping Pod 2.4 x 3 m NOT INSULATED	6 m ²	2 people	KIT: 3.1 x 1.2 x 2.6 m Assembled: 3.1 x 2.4 x 2.6m	Pod made from spruce; Roof covered with bitumen shingles of your selected color; Opening window in the back wall; Double doors with a lock and the double glass windows; One room inside. Price is without furniture.	North spruce/ Thermowood	With or without 0.6 m terrace at the front One room inside
Camping Pod 2.4 x 3.5 m NOT INSULATED	7.5 m ²	2-3 people	KIT: 3.6 x 1.2 x 2.6 m Assembled: 3.6 x 2.4 x 2.6m	Pod made from spruce; Roof covered with bitumen shingles of your selected color; Opening window in the back wall; Double doors with a lock and the double glass windows; One large room inside. Price is without furniture.	North spruce/ Thermowood	With or without 0.6 m terrace at the front One room inside
Camping Pod 2.4 x 5.9 m NOT INSULATED	13.2 m ²	2-3 people <i>comfort sleeping place</i>	KIT: 5.9 x 1.2 x 2.6 m Assembled: 5.9 x 2.4 x 2.6 m	Pod made from spruce; Roof covered with bitumen shingles of your selected color; Opening window in the back wall; Double doors with a lock and the double glass windows; Two rooms inside: living and shower room. Mini wardrobe and shelves for things. Price is without furniture.	North spruce/ Thermowood	Without terrace Two rooms inside
Camping Pod 3.2 x 4.8 m NOT INSULATED	13.1 m ²	2-3 people <i>comfort sleeping place</i>	KIT: 4.9 x 1.2 x 2.6 m	Pod made from spruce; Roof covered shingles of your selected color; Opening window in the back wall; Double doors with a lock and the double glass windows; Two rooms inside. Price is without furniture.	North spruce/ Thermowood	With or without 0.6 m terrace at the front Two rooms inside
Camping Pod 3.2 x 5.9 m NOT INSULATED	16.3 m ²	2-3 people <i>comfort sleeping place</i>	KIT: 5.9 x 1.2 x 2.6 m	Pod made from spruce; Roof covered with bitumen shingles of your selected color; Double opening window in the back wall; Double doors with a lock and the double glass windows; Two windows in front wall. Two rooms inside: living and shower room. Mini wardrobe and shelves for things. Price is without furniture.	North spruce/ Thermowood	Without terrace Two rooms inside

IMPORTANT

The same size camping pod from spruce or thermowood is the same set and layout.

SLEEPING BARRELS

COMFORTABLE OUTDOOR LIVING

Sleeping Barrels are different from the pods in their shape. Barrels are round and look stylish. Available size from tiny barrel to large sleeping barrel (about 5.8 m length).



BARREL ICE-VIKING 3 x 4.8



Bigger internal and floor space than in the standard sleeping barrels.

INSIDE



Sleeping barrel Ice-Viking: sleeping space.

STANDARD SET

- Barrel made from spruce;
- Roof covered with bitumen shingles of your selected color;
- Stainless steel tightening bands;
- One opening window in the back wall;
- Door with a lock and a hexagon glass window;
- Two rooms inside: a sleeping room and a sitting room;
- Available to make sleeping space at sitting room;
- Sleeping room with a sleeping space: 2 x 2.3 m;
- Wall partition with the entrance;
- Small benches at the entrance.

TECHNICAL SPECIFICATION

..... Shape Oval
..... External dimension (W x L) 4860 x 2952 mm
..... Total high (H) 2501 mm
..... Inside area 9.5 m ²
..... Wall thickness 38 mm
..... Size of doors (W x H) 700 x 1725 mm
..... Number of windows 1
..... Number of opening windows 1
..... Group of people 4-8 persons
..... Weight 1880 kg
..... Wood Spruce
..... Size of terrace (W x D) 2322 x 450 mm

INSIDE PLAN

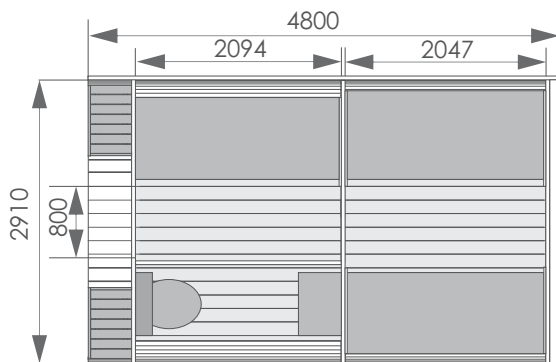

This sleeping barrel has two rooms which you can turn into any space you need. Also available have an area for WC room. Bunk beds are available in the sleeping area.



Sleeping barrel Ice-Viking: living room and WC room.



Sleeping barrel Ice-Viking: fragment from the top.

ROOF COLOR



Black shingles



Green shingles



Red shingles

TRANSPORTATION AND ASSEMBLY

The sleeping barrel Ice-Viking is delivered to a customer **not assembled**, but fully complete, with detailed assembly instructions and drawings, and packed on a pallet (KIT). Two people can assemble Sleeping Barrel Ice - Viking 3x 4.8 m in 10 hours.

Size of a KIT (L x W x H): 4.9 x 1.2 x 2.6 m.

LAYOUT

Terrace: 0.3 m length terrace without benches for 0.45 m length terrace with small benches.

Slide wall „Ice-Viking“: wooden slide door with decorative glass.



The interior of Community Barrel. Furnitures are included in standard set.

Thickness of the barrel walls is 38 mm; thickness of the solid wood flooring is 28 mm. Community barrel is 2.2 m wide and 2.4 m high.

INSIDE PLAN

STANDARD SET

- Barrel made from spruce;
- Roof covered with bitumen shingles of your selected color;
- Stainless steel tightening bands;
- Four opening windows;
- Doors with a lock and a big windows;
- One room inside with two benches and big table (from laminated plywood);
- Two entrances (in the front and in the back wall).

TECHNICAL SPECIFICATION

Shape	Round-barrel
External dimension (W x L)	Ø2335 x 4460 mm
Total high (H)	2393 mm
Inside area	9 m ²
Wall thickness	38 mm
Size of doors (W x H)	700 x 1810 mm
Size of windows (W x H)	380 x 680 mm
Number of windows	4
Number of opening windows	4
Group of people	12-15 persons
Weight	1200 kg
Wood	Spruce

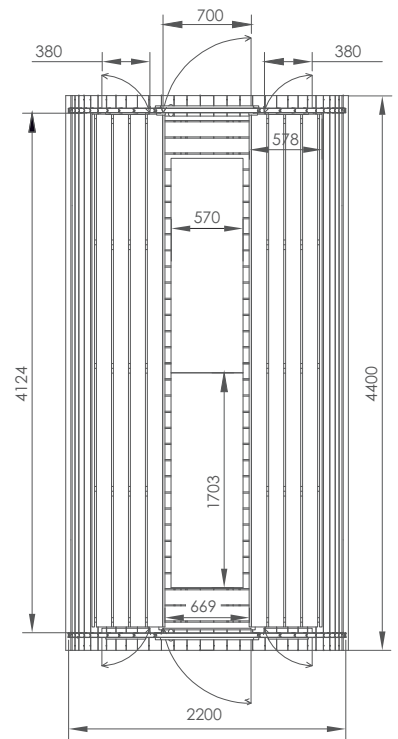
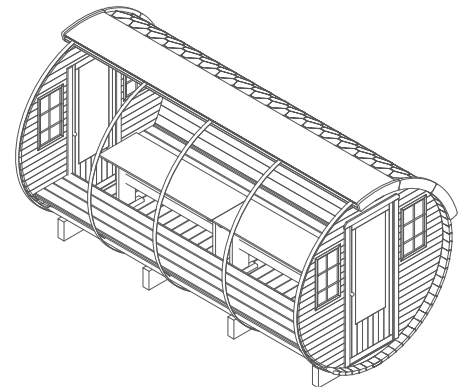

ROOF COLOR



Black shingles



Green shingles



Red shingles

TRANSPORTATION AND ASSEMBLY

The Community Barrel is delivered to a customer fully **assembled** or **not-assembled**, but fully complete, with detailed assembly instructions and drawings, and packed on a pallet (KIT). Two people can easily assemble Community Barrel 2.2x4.4 m in 8 hours.

Size of a assembled cargo (L x W x H): 4.5x2.32x2.4 m.
Size of a KIT (L x W x H): 4.5x1.2x1.3 m.

DOOR HANDLE

- Wooden knob;
- Wooden door handle;
- Metal door handle.

“With this product you can gather all family or friends in one place and not be afraid of bad weather. Imagine rainy day with your friends in Community Barrel playing board games or just catching up with each other!”

SLEEPING BARREL Ø2.2 x 3.3



FURNITURE INCLUDED

This barrel can accommodate two adults and one children.



Tiny Sleeping Barrel 2.2 x 3.3 m. Available design by special order. Rustic style door with glass tempered hexagon window.

STANDARD SET

- Barrel made from spruce;
- Roof covered with bitumen shingles of your selected color;
- Stainless steel tightening bands;
- One opening window in the back wall;
- Two opening windows in front wall;
- Doors with a lock and a double glass window;
- Two rooms inside: a sleeping room and a sitting room; 3 sleeping places;
- Sitting room with two benches and a sliding table;
- Two easily inserted wooden panels between the benches - transform into a single bed;
- Sleeping room with a sleeping space: 2 x 1.68 m;
- All furnitures included in the price.

TECHNICAL SPECIFICATION

Shape	Barrel
External dimension (W x L)	Ø2240 x 3300 mm
Total high (H)	2394 mm
Inside area	5.4 m ²
Wall thickness	38 mm
Size of door (W x H)	690 x 1800 mm
Size of front windows (W x H)	380 x 657 mm
Size of back window (W x H)	880 x 510 mm
Number of windows	3
Number of opening windows	3
Group of people	2-3 persons
Weight	900-1000 kg
Wood	Spruce

INSIDE PLAN



ROOF

6 layer bitumen tiles consists of durable and highly resistant fiber glass base coated with polymer-reinforced bitumen mix made of high quality bitumen and aggregate. The top layer of tiles is surfaced with mineral granules that lend color to the tiles and ensure high UV protection and other weather conditions resistance qualities. The

granules are painted in high temperature using thermal method pigment being burned-in into the surface of granules what guarantees long durability of the color. The bottom of tiles is coated with adhesive polymer-reinforced bitumen layer protected with easily removed silicon membrane.

ROOF COLOR



Black shingles



Green shingles



Red shingles

TRANSPORTATION AND ASSEMBLY

The barrel can be delivered to a customer as fully assembled or not assembled, with detailed assembly instructions and drawings. It is packed on a pallet (KIT).

Two people can assemble this barrel within 9 hours.

Size of a assembled cargo (L x W x H):

3.3 x 2.32 x 2.4 m.

Size of a KIT (L x W x H): 3.3 x 1.2 x 1.3 m.

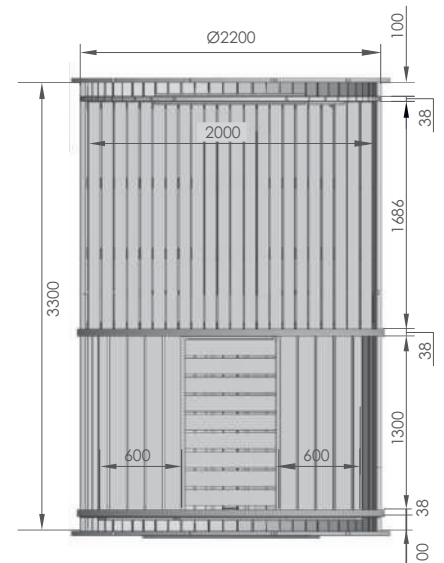

SLEEPING BARREL Ø2.2 x 3.3

WITH BUNK BED



FURNITURE INCLUDED

This barrel can accommodate two adults and 2-3 children.



Sleeping Barrel 2.2 x 3.3 m. with bunk bed. More light inside because of the 2 opening windows in the back wall.

STANDARD SET

- Barrel made from spruce;
- Roof covered with bitumen shingles of your selected color;
- Stainless steel tightening bands;
- Two opening windows in the back wall;
- Two opening windows in front wall;
- Doors with a lock and a double glass window;
- Two rooms inside: a sleeping room and a sitting room; 4-5 sleeping places;
- Sitting room with two benches;
- Sleeping room with a bunk bed;
- All furnitures are included in the price;
- Ventilation.

TECHNICAL SPECIFICATION

Shape	Barrel
External dimension (W x L)	Ø2240 x 3300 mm
Total high (H)	2394 mm
Inside area	5.4 m ²
Wall thickness	38 mm
Size of door (W x H)	690 x 1800 mm
Size of front windows (W x H)	380 x 657 mm
Size of back windows (W x H)	880 x 510 mm
Number of windows	4
Number of opening windows	4
Group of people	5-6 persons
Weight	900-1000 kg
Wood	Spruce

INSIDE PLAN



High between the bunk bed is 824 mm. First floor bed width is 1600 mm and second floor bed width is 2000 mm.

ROOF

6 layer bitumen tiles consists of durable and highly resistant fiber glass base coated with polymer-reinforced bitumen mix made of high quality bitumen and aggregate. The top layer of tiles is surfaced with mineral granules that lend color to the tiles and ensure high UV protection and other weather conditions resistance qualities. The

granules are painted in high temperature using thermal method pigment being burned-in into the surface of granules what guarantees long durability of the color. The bottom of tiles is coated with adhesive polymer-reinforced bitumen layer protected with easily removed silicon membrane.

ROOF COLOR



Black shingles



Green shingles



Red shingles

TRANSPORTATION AND ASSEMBLY

The barrel can be delivered to a customer as fully assembled or not assembled, with detailed assembly instructions and drawings. It is packed on a pallet (KIT). Two people can assemble this barrel within 9 hours. Size of a assembled cargo (L x W x H): 3.1 x 2.32 x 2.4 m; Size of a KIT (L x W x H): 3.1 x 1.2 x 1.3 m.

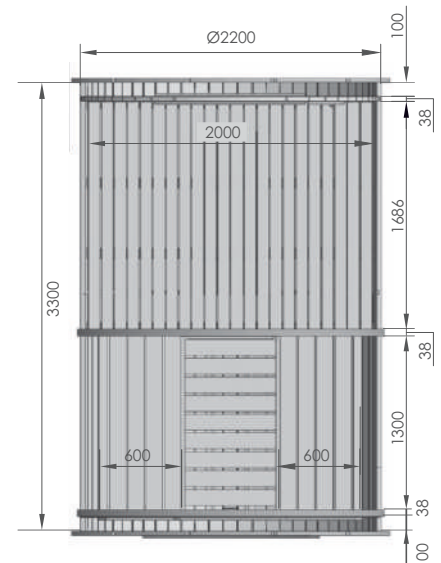

SLEEPING BARREL Ø2.2 x 4

CLASSIC



FURNITURE INCLUDED

30 cm wide terrace with two outdoor benches;
Locable door with rustic hexagonal window from double glass.



STANDARD SET

- Barrel made from spruce;
- Roof covered with bitumen shingles of your selected color;
- Stainless steel tightening bands;
- One opening double window in the back wall;
- Door with a lock and a hexagon window;
- Two rooms inside: a sleeping room and a sitting room;
- Sitting room with two benches and a sliding table;
- Available to make sleeping space at sitting room;
- Two easily inserted wooden panels between the benches - transform into a single bed;
- Sleeping room with a sleeping space: 2 x 2 m;
- Small benches at the entrance.

TECHNICAL SPECIFICATION

Shape	Round barrel
External dimension (W x L)	2236 x 4059 mm
Total high (H)	2394 mm
Inside area	7.3 m ²
Wall thickness	38 mm
Size of doors (W x H)	690 x 1800 mm
Size of double window (W x H)	715 x 675 mm
Number of windows	1
Number of opening windows	1
Group of people	2-4 persons
Weight	1300 kg
Wood	Spruce

Easily inserted wooden panel between the benches - transform into a single bed.

INSIDE PLAN

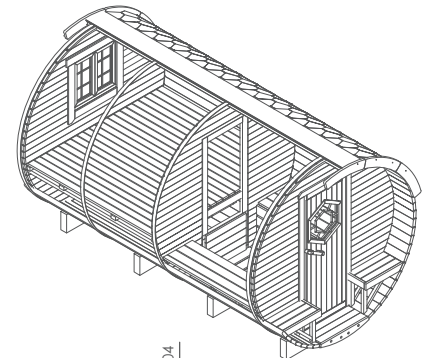

ROOF

6 layer bitumen tiles consists of durable and highly resistant fiber glass base coated with polymer-reinforced bitumen mix made of high quality bitumen and aggregate. The top layer of tiles is surfaced with mineral granules that lend color to the tiles and ensure high Uvprotection and other weather conditions resistance qualities. The

granules are painted in high temperature using thermal method pigment being burned-in into the surface of granules what guarantees long durability of the color. The bottom of tiles is coated with adhesive polymer-reinforced bitumen layer protected with easily removed silicon membrane.

ROOF COLOR



Black shingles



Green shingles



Red shingles

TRANSPORTATION AND ASSEMBLY

Sleeping Barrel 4 x 2.2 m is delivered to the customer **assembled** or not **assembled** with detailed assembly instructions and drawings, and packed on a pallet (KIT). Two people can easily assemble Sleeping Barrel 4x2.2m in 10 hours.

Size of the KIT: 4.1 x 1.2 x 1.3 m;

Assembled (L x W x H): 4.1 x 2.32 x 2.4 m.

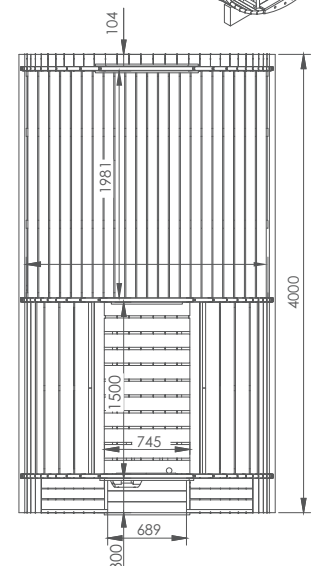

SLEEPING BARREL Ø2.2 x 4.4



Two adults and two children can easily fit in Sleeping barrel 2.2 x 4.4 m.

Furniture included: there is a double bed in the sleeping area, sliding table in the sitting room - it can be hidden under the bed. There are two benches one against another and two easily inserted wooden panels between the benches - transform into a single bed.

STANDARD SET

- Barrel made from spruce;
- Roof covered with bitumen shingles of your selected color;
- Stainless steel tightening bands;
- One opening window in the back wall;
- Two opening windows in front wall;
- Door with a lock and a window;
- Two rooms inside: sleeping and sitting room;
- Sitting room with two benches and a sliding table;
- Available to make sleeping space at sitting room;
- Sleeping room with a sleeping space: 2 x 2 m.

ROOF

6 layer bitumen tiles consists of durable and highly resistant fiber glass base coated with polymer-reinforced bitumen mix made of high quality bitumen and aggregate. The top layer of tiles is surfaced with mineral granules that lend color to the tiles and ensure high Uvprotection and other weather conditions resistance qualities. The

TECHNICAL SPECIFICATION

Shape	Round barrel
External dimension (W x L)	Ø2245 x 4400 mm
Total high (H)	2394 mm
Inside area	9 m ²
Wall thickness	38 mm
Size of doors (W x H)	690 x 1800 mm
Size of windows (W x H)	880 x 510 mm
Size of front windows (W x H)	380 x 675 mm
Number of windows	3
Number of opening windows	3
Group of people	2-5 persons
Weight	1350 kg
Wood	Spruce

granules are painted in high temperature using thermal method pigment being burned-in into the surface of granules what guarantees long durability of the color. The bottom of tiles is coated with adhesive polymer-reinforced bitumen layer protected with easily removed silicon membrane.

ROOF COLOR



Black shingles



Green shingles



Red shingles

TRANSPORTATION AND ASSEMBLY

Sleeping Barrel 2.2 x 4.4 m is delivered to the customer with detailed assembly instructions and drawings, and packed on a pallet (KIT). Two people can easily assemble Sleeping Barrel in 10 hours.

Size of a assembled cargo (L x W x H): 4.5 x 2.3 x 2.4 m.

Size of a KIT (L x W x H): 4.5 x 1.2 x 1.3 m.



Sliding table in the sitting room it can be hidden when it is not needed.

INSIDE PLAN

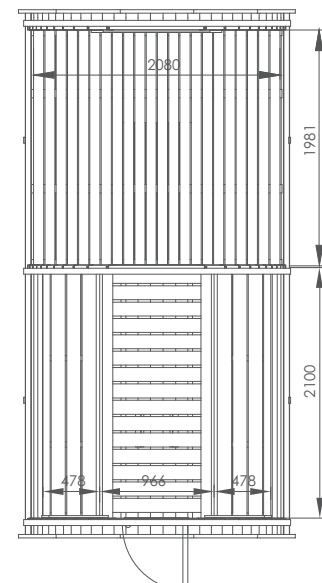

SLEEPING BARREL Ø2.2 x 4.4

WITH BUNK BED



FURNITURE INCLUDED



Sleeping Barrel 2.2 x 4.4 m. with bunk bed. More light inside because of the 2 opening windows in the back wall.

STANDARD SET

- Barrel made from spruce;
- Roof covered with bitumen shingles of your selected color;
- Stainless steel tightening bands;
- Two opening windows in the back wall;
- Two opening windows in front wall;
- Door with a lock and a double glass window;
- Two rooms inside: a sleeping room and a sitting room; 5-6 sleeping places;
- Sitting room with two benches;
- Sleeping room with a bunk bed;
- All furniture included in the price;
- Ventilation.

TECHNICAL SPECIFICATION

Shape	Barrel
External dimension (W x L)	Ø2245 x 4400 mm
Total high (H)	2394 mm
Inside area	9 m ²
Wall thickness	38 mm
Size of door (W x H)	710 x 1800 mm
Size of front windows (W x H)	380 x 657 mm
Size of back windows (W x H)	880 x 510 mm
Number of windows	4
Number of opening windows	4
Group of people	4-8 persons
Weight	1400 kg
Wood	Spruce

INSIDE PLAN



High between the bunk bed is 824 mm. First floor bed width is 1600 mm and second floor bed width is 2000 mm.

ROOF

6 layer bitumen tiles consists of durable and highly resistant fiber glass base coated with polymer-reinforced bitumen mix made of high quality bitumen and aggregate. The top layer of tiles is surfaced with mineral granules that lend color to the tiles and ensure high UV protection and other weather conditions resistance qualities. The

granules are painted in high temperature using thermal method pigment being burned-in into the surface of granules what guarantees long durability of the color. The bottom of tiles is coated with adhesive polymer-reinforced bitumen layer protected with easily removed silicon membrane.

ROOF COLOR



Black shingles



Green shingles



Red shingles

TRANSPORTATION AND ASSEMBLY

The barrel can be delivered to a customer as fully assembled or not assembled, with detailed assembly instructions and drawings. It is packed on a pallet (KIT).

Two people can assemble this barrel within 9 hours.

Size of a assembled cargo (L x W x H):

4.4 x 2.35 x 2.5 m.

Size of a KIT (L x W x H): 4.4 x 1.2 x 2.5 m.

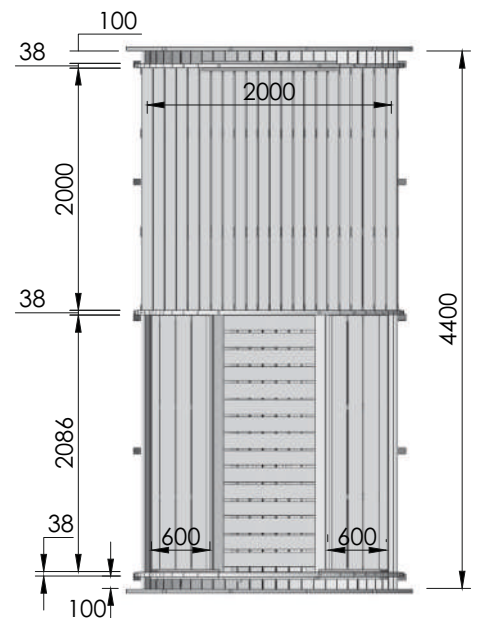

DELIGHT CAMPING 2.4 x 4.3



TWO ROOMS
INSIDE

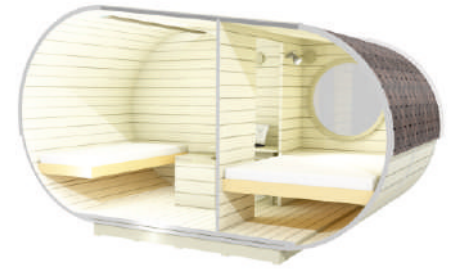

As option you can have free standing furniture and product will be with 2 separate bedrooms

STANDARD SET

- Delight Camping is made from spruce;
- Roof covered with bitumen shingles of your selected color;
- Stainless steel tightening bands;
- Round window in a back wall;
- Door with a lock and big tempered glass window;
- Two rooms inside: 1st room size is 5.44 m²; 2nd room size 3.30 m²;
- 2 pcs of ventilation.

TECHNICAL SPECIFICATION

Shape	Oval
External dimension (W x L)	4290 x 2480 mm
Total high (H)	2500 mm
Inside area	5.6 m ²
Wall thickness	38 mm
Size of door (W x H)	700 x 1800 mm
Size of back window (W x H)	Ø 850mm
Number of windows (not opening)	1
Group of people	6-8 persons
Weight	1200 kg
Wood	Spruce

INSIDE VIEW



PLAN

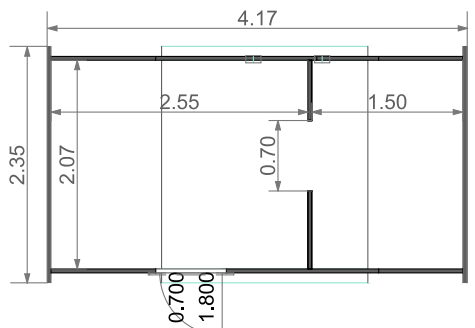
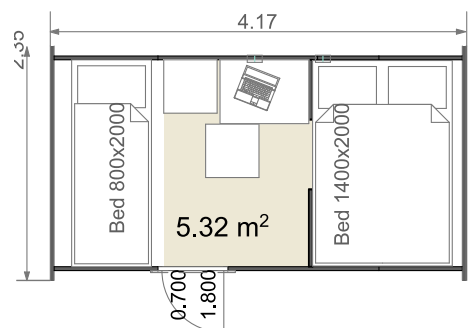

High between the bunk bed is 824 mm. First floor bed width is 1600 mm and second floor bed width is 2000 mm.



Standard back wall



Interior example of Delight Camping

ROOF COLOR



Black shingles



Green shingles



Red shingles

TRANSPORTATION AND ASSEMBLY

The barrel can be delivered to a customer as fully assembled or not assembled, with detailed assembly instructions and drawings. It is packed on a pallet (KIT). Two people can assemble this product within 15 hours.

Size of a assembled cargo (L x W x H): 4.3 x 2.4 x 2.5 m.

Size of a KIT (L x W x H): 4.3 x 1.2 x 2.5 m.

CAMPING CABINS

STYLISH CAMPING IN RUSTIC

The Camping cabins in the country style is great for camping, it looks cozy like mountain huts. Possible options: single cabins, double cabins and cabins with extensions. The cabins have from 1 to 3 rooms inside, which can accommodate living, sleeping and shower rooms.



CAMPING CABIN 9.2

A roof is made of six elements and covered with bitumen shingles

Double glazed windows

Rustic roof porch

The door is decorated with an original hexagonal window

Cabin walls are made of rounded spruce boards

Floor is easily assembled from separate components



Roof window is not opening.
The glass is clean and tempered, 8 mm thick.

ROOF

6 layer bitumen tiles consists of durable and highly resistant fiber glass base coated with polymer-reinforced bitumen mix made of high quality bitumen and aggregate. The top layer of tiles is surfaced with mineral granules that lend color to the tiles and ensure high UV-protection and other weather conditions resistance qualities. The granules are painted in high temperature using thermal method pigment being burned-in into the surface of granules what guarantees long

durability of the color. The bottom of tiles is coated with adhesive polymer-reinforced bitumen layer protected with easily removed silicon membrane. As a result of sun heat exposure the overlapped tiles stick to each other thus forming a double hydro-insulating layer, which guarantees excellent leak resistance of the roof. Bitumen tiles can be used both for new construction and roof repair work. You may choose black, green or red color bitumen tiles.

STANDARD SET

Wall, floor, roof panels from spruce;

Roof covered with bitumen shingles of your selected color;

3 double glass windows (1 of them is opening);

Door with a lock and a hexagon window.

TECHNICAL SPECIFICATION

Shape	Hexagon – 6 corners
External dimension	3770 x 3265 mm
Total high	3062 mm
Inside area	9.2 m ²
Size of door (W x H)	780 x 1500 mm
Size of window (W x H)	880 x 510 mm
Group of people	2
Weight	1200 kg
Wood	Spruce
Assembling time	Two people in 6 hours

PLAN

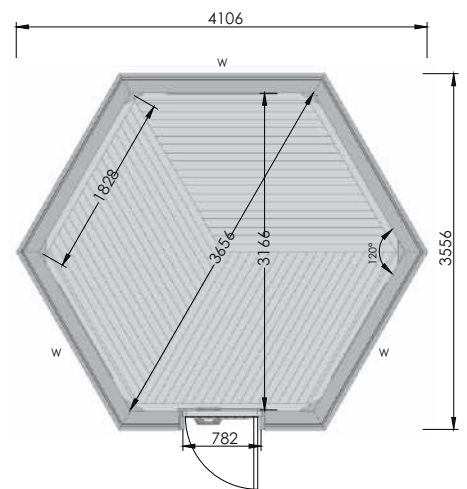

OPTIONS

Walls Height: 1 or 2 extra boards in walls;

Opening Windows: 1 from 3 (standard); 2 from 3; 3 from 3;

Insulated: roof and floor;

Available tongue and groove floors;

Roof panel with window: 1-5 pcs.



ROOF COLOR



Black shingles



Green shingles



Red shingles

TRANSPORTATION AND ASSEMBLY

Camping Cabin 9.2 m is delivered to the customer fully complete, with detailed assembly instructions and drawings, and packed on a pallet (KIT). Cabin components include six wall panels, six roof panels and three floor panels.

Cabin 9.2 m² pallet size (L x W x H): 2.4 x 1.2 x 2.55 m.

CAMPING CABIN 14.9

The cabin is lockable, and there is a small porch with a roof at the entrance

Grill Cabin 14.9 m² components include eight wall panels, eight roof panels and eight floor panels like in Cabin 16.5 m²



Camping Cabin 14.9 project

High-quality materials ensure the longevity of a camping cabin and easy use. Eight cabin walls are made of rounded spruce boards with the dimensions 45 x 145 mm.

ROOF

6 layer bitumen tiles consists of durable and highly resistant fiber glass base coated with polymer-reinforced bitumen mix made of high quality bitumen and aggregate. The top layer of tiles is surfaced with mineral granules that lend color to the tiles and ensure high UV-protection and other weather conditions resistance qualities. The granules are painted in high temperature using thermal method pigment being burned-in into the

surface of granules what guarantees long durability of the color. The bottom of tiles is coated with adhesive polymer-reinforced bitumen layer protected with easily removed silicon membrane. As a result of sun heat exposure the overlapped tiles stick to each other thus forming a double hydro-insulating layer, which guarantees excellent leak resistance of the roof. Bitumen tiles can be used both for new construction and roof repair work.

STANDARD SET

Wall, floor, roof panels from spruce;

Roof covered with bitumen shingles of your selected color;

4 double glass windows (2 of them are opening);

Door with a lock and a hexagon window.

TECHNICAL SPECIFICATION

Shape	Octagonal – 8 corners
External dimension (W x D)	5168 x 4778 mm
Total high (H)	3325 mm
Inside area	14.9 m ²
Size of door (W x H)	780 x 1500 mm
Size of window (W x H)	880 x 510 mm
Number of windows	4
Number of opening windows	2
Group of people	2 persons
Weight	1600 kg
Wood	Spruce

INSIDE PLAN

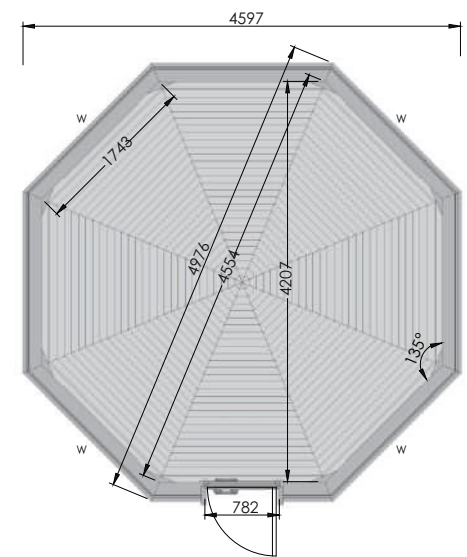

OPTIONS

Walls Height: 1 or 2 extra boards in walls

Opening Windows: 2 from 4 (standard); 3 from 4; 4 from 4;

Insulated: roof and floor;

Available tongue and groove floors;

Curtains Set: brown or blue.

ROOF COLOR



Black shingles



Green shingles



Red shingles

TRANSPORTATION AND ASSEMBLY

This Camping Cabin 14.9 m is delivered to the customer fully complete, with detailed assembly instructions and drawings, and packed on a pallet (KIT).

Two people can easily assemble cabin in 9 hours.

Size of the cargo (L x W x H): 3.5 x 1.2 x 2.55 m;

Weight: 1600 kg.



Set of brown.



Set of blue.

CAMPING CABIN 16.5

The cabin is lockable, and there is a small porch with a roof at the entrance.

Camping cabin components include eight wall panels, eight roof panels and eight floor panels.

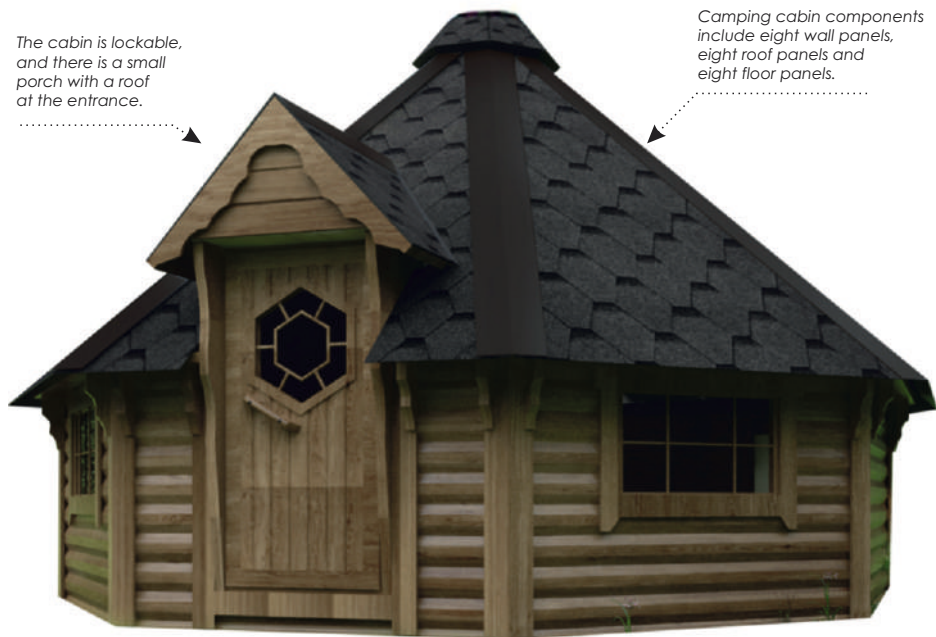

The fragment of interior.

High-quality materials ensure the longevity of a camping cabin and easy use. Eight cabin walls are made of rounded spruce boards with the dimensions 45 x 145 mm.



Camping Cabins 16.5 m² are built in the traditional Lapish style of Northern Finland and offer the year round living culture that the Scandinavians have been enjoying for many years. The ability to use your cabin all year round is something that we offer for your relaxation.

STANDARD SET

Wall, floor, roof panels from spruce;

Roof covered with bitumen shingles of your selected color;

4 double glass windows (2 of them are opening);

Doors with a lock and a hexagon window.

TECHNICAL SPECIFICATION

Shape	Octagonal – 8 corners
External dimension (W x D)	5522 x 5106 mm
Total high (H)	3446 mm
Inside area	16.5 m ²
Size of door (W x H)	780 x 1500 mm
Size of window (W x H)	880 x 510 mm
Number of windows	4
Number of opening windows	2
Group of people	2-4 persons
Weight	1650 kg
Wood	Spruce

INSIDE PLAN

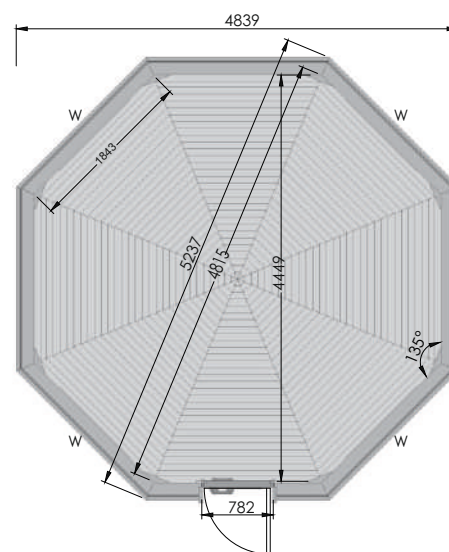

ROOF COLOR



Black shingles



Green shingles



Red shingles

TRANSPORTATION AND ASSEMBLY

This Camping Cabin 16.5 m is delivered to the customer fully complete, with detailed assembly instructions and drawings, and packed on a pallet (KIT).

Three people can assemble Camping Cabin in 7 hours.

Size of the cargo (L x W x H): 3.5 x 1.2 x 2.55 m.

OPTIONS

Walls height: 1 or 2 extra boards in walls;

Opening windows: 2 from 4 (standard); 3 from 4; 4 from 4;

Insulated: roof and floor;

Available tongue and groove floors;

Curtains Set: brown or blue;

CAMPING CABIN 9.2 + 9.2



STANDARD SET

Wall, floor, roof panels from spruce;

Roof covered with bitumen shingles of your selected color;

7 double glass windows (2 of them are opening);

Door with a lock and a hexagon window;

Connection's size: 1.95 x 1.99 m;

Two rooms inside.

TECHNICAL SPECIFICATION

Shape	Hexagon + rectangle + hexagon
External dimension (W x D)	9342 x 4423 mm
Total high (H)	3062 mm
Inside area	9.2 m ² + 3.76 m ² + 9.2 m ²
Size of door (D x H)	780 x 1500 mm
Size of window (D x H)	880 x 510 mm
Number of windows	7
Number of opening windows	2
Group of people	8
Weight	2800 kg
Wood	Spruce

OPTIONS

Walls height: 1 or 2 extra boards in walls.

Opening windows: 2 from 7 (standard); 3 from 7; 4 from 7; 5 from 7; 6 from 7 or 7 opening windows from 7.

Insulated: roof and floor.

Available: tongue and groove floors.

Curtains set: brown or blue.

CUT VIEW

The details of the walls, floor and roof you get in segments, not a single boards. Components include 14 wall panels, 14 roof panels and 13 floor panels.

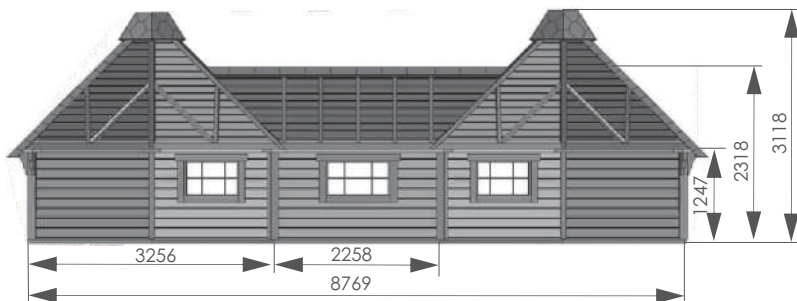

ROOF COLOR



Black shingles



Green shingles



Red shingles

TRANSPORTATION AND ASSEMBLY

This Camping Cabin is delivered to the customer fully complete, with detailed assembly instructions and drawings, and packed on a pallet (KIT). Two people can assemble double camping cabin 9.2 + 9.2 m² in 15 hours.

Double camping cabin is packed on two pallets (L x W x H): 1st pallet is 4 x 1.2 x 2.55 m and 2nd pallet is 2.5 x 1.2 x 2.5 m.



Set of brown.

Set of blue.

Roof panel with window: 1-4 pcs



Roof window is not opening. The glass is clean and tempered, 8 mm thick.

CAMPING CABIN 16.5 + 16.5

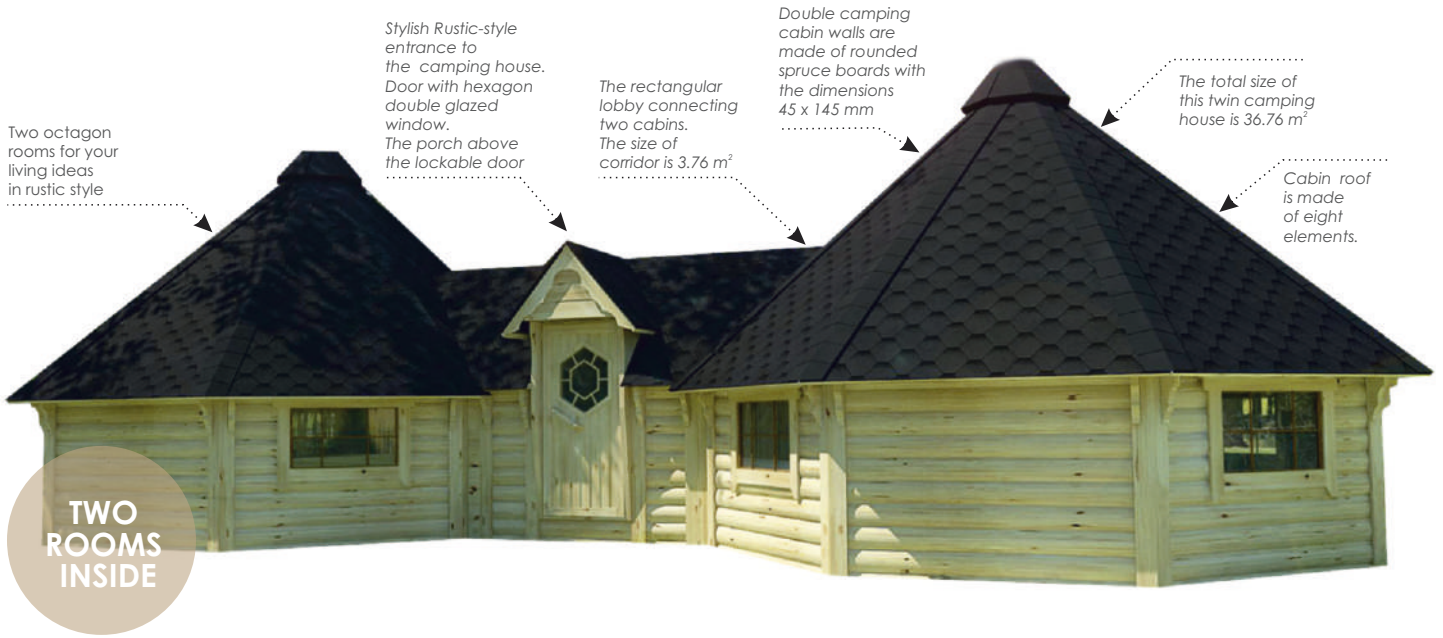

STANDARD SET

Wall, floor, roof panels from spruce;

Roof covered with bitumen shingles of your selected color;

9 double glass windows (4 of them are opening);

Door with a lock and a hexagon window;

Connection's size: 1.95 x 1.99 m;

Two rooms inside.

TECHNICAL SPECIFICATION

Shape	Octagonal + rectangle + octagonal
External dimension (W x D)	11899 x 5106 mm
Total high (H)	3446 mm
Inside area	16.5 m ² + 3.76 m ² + 16.5 m ²
Size of door (W x H)	780 x 1500 mm
Size of window (W x H)	880 x 510 mm
Number of windows	9
Number of opening windows	4
Group of people	8 persons
Weight	2650 kg
Wood	Spruce

OPTIONS

Walls height: 1 or 2 extra boards in walls.

Opening windows: 4 from 9 (standard); 5 from 9; 6 from 9; 7 from 9; 8 from 9 or 9 opening windows from 9.

Insulated: roof and floor.

Available tongue and groove floors.

Curtains set:

INSIDE PLAN

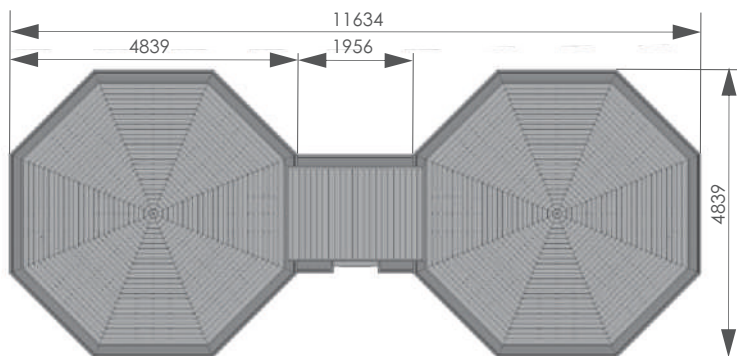

Floor is easily assembled from separate components.



ROOF COLOR



Black shingles



Green shingles



Red shingles

TRANSPORTATION AND ASSEMBLY

This Camping Cabin is delivered to the customer fully complete, with detailed assembly instructions and drawings, and packed on a pallet (KIT).

Three people can assemble cabin in 14 hours.

Size of the cargo (L x W x H): 4 x 1.2 x 2.55 m + 3.5 x 1.2 x 2.55 m.

CAMPING CABIN 9.2

WITH 2 EXTENSIONS

Stylish Rustic-stylen entrance to the camping cabin. Door with hexagon double glazed window. The porch above the lockable door

Two extensions for your living ideas in rustic style

Cabin roof is made of six elements

The size of extension is 4.3 m² (L x W - 2.5 x 1.6 m)

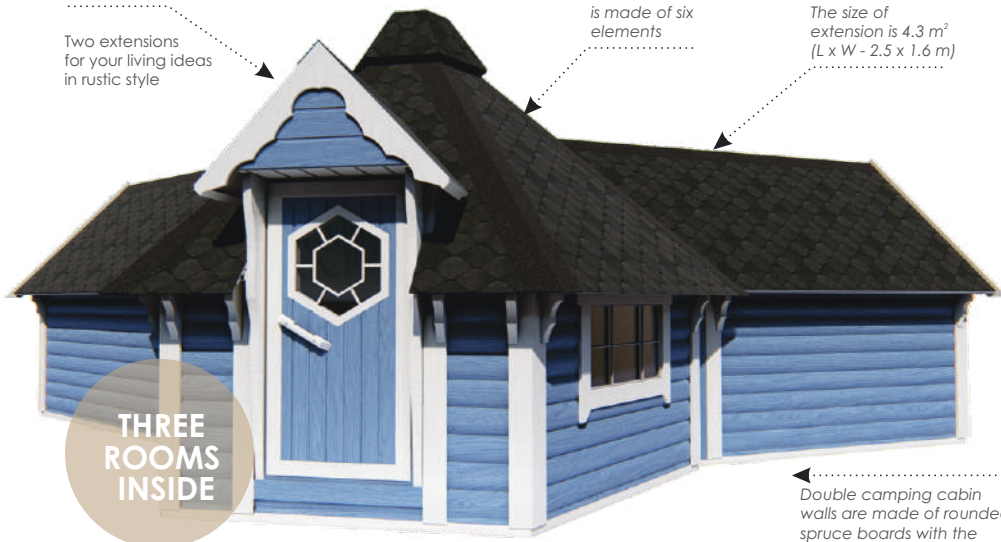

THREE ROOMS INSIDE

Double camping cabin walls are made of rounded spruce boards with the dimensions 45 x 145 mm

OPTIONS

Walls height: 1 or 2 extra boards in walls.

Available insulated roof.

Available insulated floor.

Available tongue and groove floors.

Roof Color



Black shingles

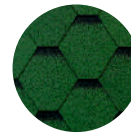

Green shingles



Red shingles

Opening windows: 3 from 5 (standard); 4 from 5; 5 from 5.

Curtains set: brown or blue.

Roof panel with window: 1-3 pcs.

STANDARD SET

Wall, floor, roof panels;

Roof covered with bitumen shingles of your selected color;

5 double glass windows (three of them are opening);

Lockable door with double glazing hexagonal window;

3 rooms: 6-corners cabin and 2 rectangular extensions.

TECHNICAL SPECIFICATION

Shape	Hexagonal + rectangle + rectangle
External dimension (W x D)	8150 x 4430 mm
Total high	3062 mm
Inside area	17.2 m ²
Size of door (W x H)	780 x 1500 mm
Size of window (W x H)	880 x 510 mm
Number of windows	5
Number of opening windows	3
Available	2-4 persons for comfortable living
Weight	170 kg
Wood	Spruce
The thickness of floor	18 mm
The thickness of walls	45 mm
The thickness of roof	18 mm

LAYOUT

A tiny and cozy and more spacious camping cabin with two extensions gives substantial space for all your belongings, both on a temporary or a permanent basis.

The cabin with two extensions is a bigger and more spacious structure, thus it offers more liveable spaces that you can use as a storage area.

This cabin are also good sources of campings. Three separate spaces make it possible to arrange the cottage to the living room, bedroom and bathroom spaces.

TRANSPORTATION AND ASSEMBLY

This camping cabin is delivered to the customer fully complete, with detailed assembly instructions and drawings, and packed on a pallet (KIT).

Size of the cargo (L x W x H): 4.5 x 1.2 x 2.5 m + 2 x 1.2 x 2.5 m.

INSIDE PLAN

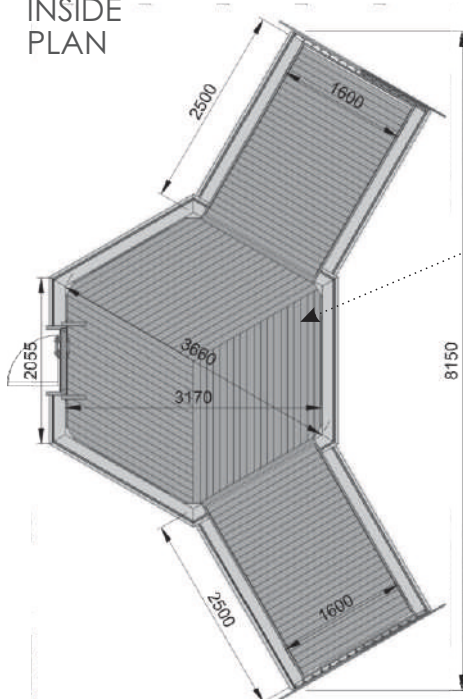

Floor, walls and roof is easily assembled from separate components.

The hexagon Camping Cabin floor is made up of 3 segments. Extensions floors are in one segment.



This is an example of how the inside of the house can be fitted.



Interior example of camping cabin 9.2 with 2 extensions.

CAMPING CABIN^{16.5}

WITH 2 EXTENSIONS

Stylish Rustic-stylen entrance to the camping cabin. Door with hexagon double glazed window. The porch above the lockable door

Cabin roof is made of eight elements

The size of extension is 4.3 m² (L x W - 2.5 x 1.6 m)

Two extensions for your living ideas in rustic style

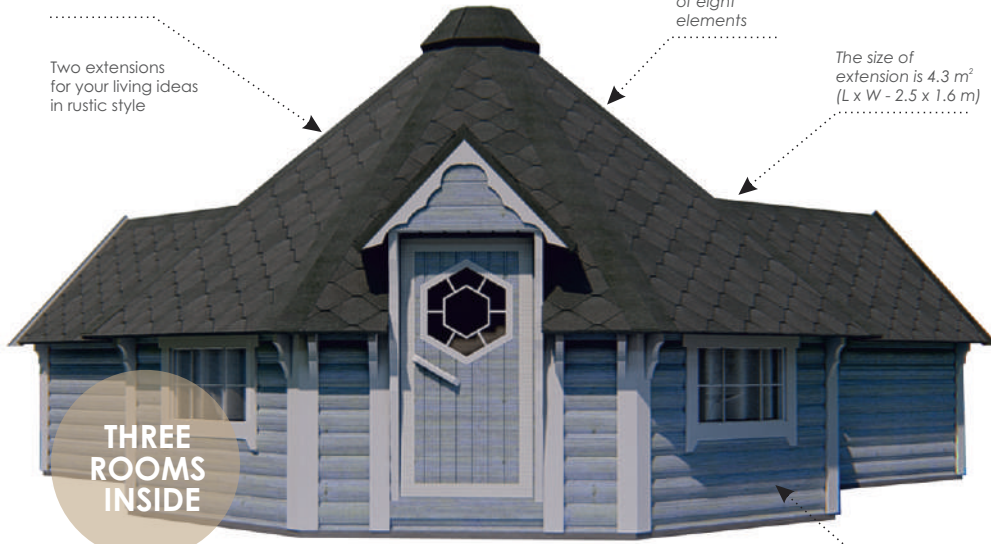

Camping cabin walls are made of rounded spruce boards with the dimensions 45 x 145 mm

OPTIONS

Walls height: 1 or 2 extra boards in walls.

Available insulated roof.

Available insulated floor.

Available tongue and groove floors.

Roof Color



Black shingles

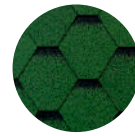

Green shingles



Red shingles

Curtains set: brown or blue.

Roof panel with window: 1-3 pcs.

STANDARD SET

Wall, floor, roof panels;

Roof covered with bitumen shingles of your selected color: red, green, black;

4 double glass windows (all of them are opening);

Lockable door with double glazing hexagonal window;

3 rooms: 8-corners cabin and 2 rectangular extensions;

TECHNICAL SPECIFICATION

Shape	Octagonal + rectangle + rectangle
External dimension (W x D)	8150 x 6240 mm
Total high (H)	3446 mm
Inside area	24.5 m ²
Size of door (W x H)	780 x 1500 mm
Size of window (W x H)	880 x 510 mm
Number of windows	4
Number of opening windows	4
Available 5-6 persons for comfortable living	
Weight	2500 kg
Wood	Spruce
The thickness of floor	18 mm
The thickness of walls	45 mm
The thickness of roof	18 mm

LAYOUT

A bigger and more spacious camping cabin gives substantial space for all your belongings, both on a temporary or a permanent basis.

The cabin with two extensions is a bigger and more spacious structure, thus it offers more liveable spaces that you can use as a storage area.

This cabins are also good sources of campings. Three separate spaces make it possible to arrange the cottage to the living room, bedroom and bathroom spaces.

INSIDE PLAN

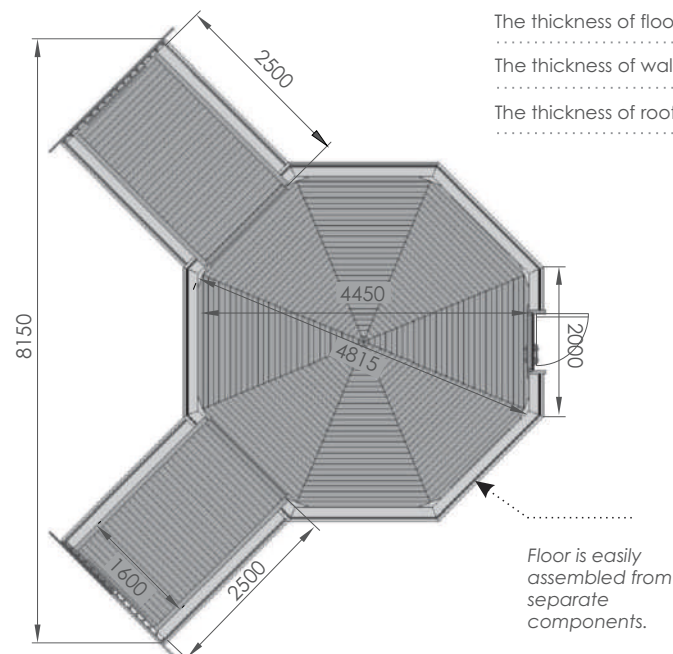

EQUIPPED TO ALL WEATHER

This camping cabin can withstand winter weather and can offer you the perfect space to relax even in winter.

Also is available to choose as an options insulated roof and floor for this cabin. Insulation: 5 cm thick stone wool.

With a insulated roof and floor panels, the camping cabin becomes more attractive for use both in summer and winter. In the summer season, the insulation keeps the heat off and the cabin does not heat up. During the winter, the insulation does not release the heat out.

TRANSPORTATION AND ASSEMBLY

This Camping Cabin is delivered to the customer fully complete, with detailed assembly instructions and drawings, and packed on a pallet (KIT).



Interior example of camping cabin
16.5 with 2 extensions

GLAMPING CUBE 3x7

INSULATED/NOT INSULATED

Living room (3 x 3 m) with two glass walls and aluminum (three rails) sliding system. The room is open, connected to the bedroom

Open bedroom (L x W) - 3 x 3 m with free glass walls panels in the front wall

Glamping cube is connected with two frames: 3 x 3 + 4 x 3 m

Closed shower and WC room (L x W) - 1 x 3 m



THREE ROOMS INSIDE

STANDARD SET (INSULATED CUBE)

- 2 insulated frames: 3 x 3 and 4 x 3 m;
- Aluminum 3 rails sliding door Raynears;
- 5 wooden glass walls with glass package;
- 16 standard insulated walls;
- 1 inner wooden door without window.

STANDARD SET (NOT INSULATED CUBE)

- 2 not insulated frames: 3 x 3 and 4 x 3 m;
- Aluminum 3 rails sliding door Alutech;
- 5 wooden glass walls with tempered glass;
- 16 standard not insulated walls;
- 1 inner wooden door without window.

INSIDE PLAN



TECHNICAL SPECIFICATION

Shape	Rectangle
External dimension (W x L)	3440 x 7570 mm
Total high (H)	2800 mm
Inside area	21 m ²
Size of inner door (W x H)	819 x 2032 mm
Size of sliding door (W x H)	3000 x 2200 mm
Size of glass wall (W x H)	1000 x 2200 mm
Group of people	2-4 persons
Weight	2800 - 2900 kg
Wood	Spruce
Insulation	50 mm stone wool

TRANSPORTATION AND ASSEMBLY

This Glamping Cube is delivered to the customer fully complete, with detailed assembly instructions and drawings, and packed on a pallet (KIT). Two - three people can assemble cabin in 14 hours.

Size of the cargo (L x W x H):
1st pallet - 3.4 x 1.2 x 2.6 m;
2nd pallet - 4.4 x 1.2 x 2.6 m.

FRAME

INSULATED. Cube frame from spruce: insulated floor and roof panels, 4 columns. Insulation - stone wool (50 mm). The frames are made from glue laminated spruce beams. Frame consists of bottom frame (100 x 140 mm), columns (140 x 140 mm), top frame (140 x 240 mm) and withstands 442 kg/m² roof load. The floor is made of 146 x 28 mm floor board.

NOT INSULATED. Cube frame from spruce: floor and roof panels, 4 columns. The frames are made from glue laminated spruce beams. Frame consists of bottom frame (100 x 140 mm), columns (140 x 140 mm), top frame (140 x 240 mm) and withstands 442 kg/m² roof load. The floor is made of 146 x 28 mm floor board.

The walls, floor and roof of our glamping Cube are insulated to lower energy costs. We use stone wool to insulate our cubes for this reason: fire resilience, thermal properties, acoustic capabilities, durability, aesthetics, water properties, circularity.

We include all of the screws, nails and fixings needed to put your garden building together. So there's no need to worry about the type of screws, or length of nails etc. You might need to get started, it's all there in the pack!

We are not big fans of OSB sheets as far as floor is concerned. So floor comes with 28 mm wooden boards from spruce.

SLIDING SYSTEM

3-RAILS SLIDING DOOR REYNAERS.

The size of aluminium 3-rails sliding doors system Reynaers is 3000 x 2200 mm. Standard set: 3 rails; System frame profile wide: 90 mm; Door profile depth of the frame and the sash: 45 mm; Single glass thickness: 4 mm; Colour: metallic/white. This is single-chamber aluminium system.

3-RAILS SLIDING DOOR ALUTECH.

Aluminium 3-rails sliding doors system size is 3000 x 2200 mm. Standard set: 3 rails; System frame profile wide: 90 mm; Door profile depth of the frame and the sash: 45 mm; Single tempered glass thickness is 4 mm; Colour: metallic/white. This is single-chamber aluminium system.

CAMPING PRODUCTS



WOODEN POUF

The pouf is made of northern spruce wood, with spacing between the plates, so air circulates easily and ensure good ventilation.



TABLE

The table is made of northern spruce wood. Table has a stable base: the feet are connected additional details. Modern design and the charm of natural wood perfectly complicated camping products.



DOUBLE BED - SOFA

The double bed is made of northern spruce. Double bed can modified into a sofa bed with support. Modern design and the charm of natural wood perfectly complicated camping pods.



SINGLE BED

The single bed is made of northern spruce wood. Bed easily fastened to the wall. Modern design and the charm of natural wood perfectly complicated camping products.



BENCH

The bench is made of northern spruce wood is sturdy and reliable. The bench has the support legs 5, so it is stable. Modern design and the charm of natural wood perfectly complicated camping products.



**KITCHEN SET FOR CAMPING POD
4.8 X 3.2 M**

The kitchen is made of northern spruce wood is sturdy and reliable. Simple design and the charm of natural wood perfectly complicated camping products. What you get: worktop; cabinets, cabinet doors, hinges and knobs. Dimensions (L x W x H): 2340 x 683 x 808 mm.



DRAWER UNDER THE SINGLE BED

The drawer is made of northern spruce wood is sturdy and reliable. Simple design and the charm of natural wood perfectly complicated camping products.



SHELF

The shelf is made of northern spruce wood is sturdy and reliable. Simple design and the charm of natural wood perfectly complicated camping products.



**SHELVE ABOVE DOUBLE
BED (CLOSED)**

The shelf is made of northern spruce wood. The shelf is closed with the door from the side of the room. From the inside (from the side of the bed) there is a niche for fitting things.

Available in Insulated Camping Pod 3.2x5.9m.

ACCESSORIES

CAMPING PRODUCTS



BENCH TRANSFORMING INTO A SINGLE BED

This multi functional piece of furniture provide great seating and sleeping space (bench easy transforms into a bed).



KITCHEN SET FOR CAMPING POD 3.2 x 5.9 M

The kitchen set is made of northern spruce wood and is sturdy. You will get: worktop, cabinets with doors, hinges and knobs.
Dimensions (L x W x H): 1435 x 600 x 808 mm.

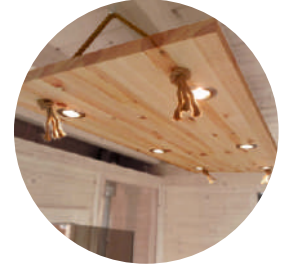

CEILING LAMP FOR GLAMPING CUBE

Spruce wood pendant light to light up your Glamping Cube.
Size: 1500 x 600 mm.



TABLE AND BENCHES SET

Modern design spruce wood table and benches set contains:

- Table on wheels (450 x 600 mm);
- Bench (450 x 1400 mm);
- Bench with backrest (800 x 1900 mm).



WHITE CUSHION SET

White imitation leather cushion set designed to fit table and benches set.



RAINWATER PIPES FOR GLAMPING CUBE

The rainwater pipes package includes straight gutter and all parts needed for installation. Down pipe package includes 2.5 m down pipe and all parts needed for installation. No need for exact measurements and calculations and easy to transport and install, as all components needed are packaged compactly in a single package, ensuring safe delivery and easy installation.

Rainwater pipes is made of plastic.
Color - brown.



Interior example of camping Pod 2.4 x 4.8 m.



REAL PRODUCTS FOR REAL PEOPLE



QUALITY, FLEXIBILITY, SHORT TERMS

www.vikingbuitenleven.nl